



Controller with Operator Interface
FT2J



Smart **AXIS**

The All-in-One Solution for Seamless Automation



IDEC CORPORATION

HMI and controller integrated in a compact structure

Space-saving compact design

Integrated control and display. Requires only one-third the depth of a PLC and HMI combined, making it suitable for use in tight spaces.

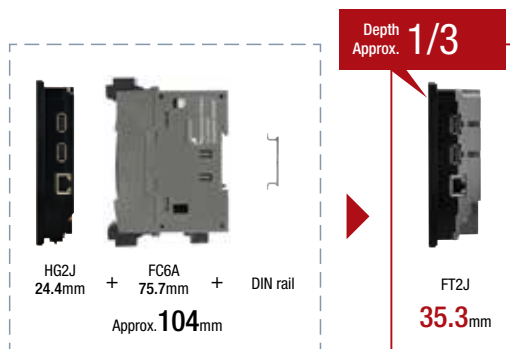

Large display

Significantly reduced slim bezel width enables an existing 5.7 inch display to be replaced by a larger and more immersive 7.0 inch display.

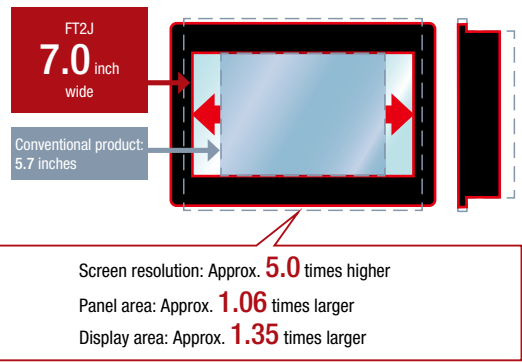

Time-saving and easy wiring

Equipped with a vibration-resistant push-in terminal block that allows tool-free wiring. The removable terminal block enables separate wiring, resulting in improved efficiency.



Environmentally-friendly

The FT2J consumes approximately 40% less power than PLC and display combined. (*1)
Also, it features a battery-free design, eliminating the need for disposable lithium batteries.

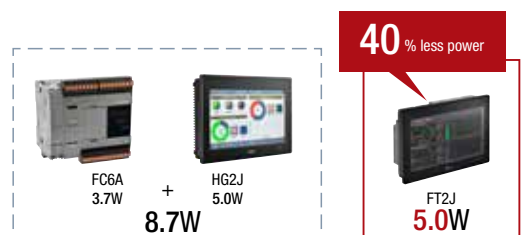

*1) Compared to when using FC6A-C24R4CE and HG2J-7UT22TF-B (equivalent product).

Wide range of control functions

Dual CPU configuration for high-speed processing

The FT2J has two CPUs working in parallel, unlike conventional products that use a single CPU for both HMI and control functions. This design enables high-speed, real-time control without compromising HMI functionality, broadening the range of compatible applications.

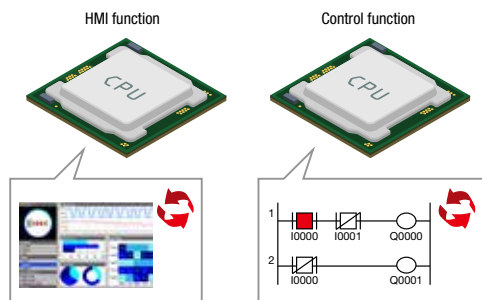

Expansion cartridge with flexible I/O expandability

Up to 2 digital I/O cartridges or analog I/O cartridges can be connected to add up to 8 digital I/O, and up to 4 analog I/O. This makes it easy to add inputs/outputs when devices are changed or updated.



Analog I/O

12-bit resolution with built-in analog I/O to control analog signals from 0 to 10V DC / 4 to 20mA. (Analog output is available on the transistor output model only.)

An analog potentiometer connected to the analog input allows for easy configuration of analog settings, such as a timer. Suitable for small-scale applications that require analog I/Os.

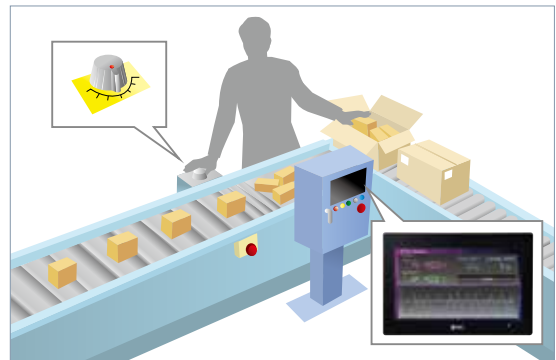

High-speed counter

The single-phase (20kHz) 4-point, single-phase (20kHz)/two-phase (10 kHz) 1-point high-speed counter is capable of counting high-speed pulses. It can be used in various applications, such as with a rotary encoder to control tracking or a flow meter to control fluid volume.

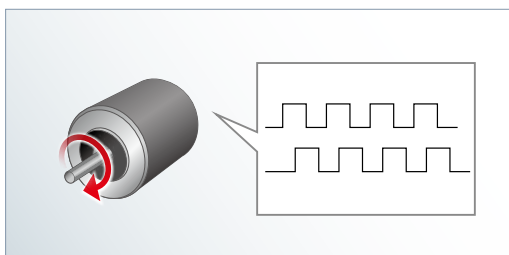

PID control

A PID algorithm with cascade control is available for applications that require temperature, flow, or pressure control.

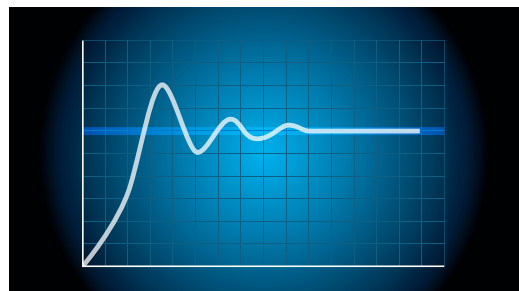

Clear and functional display

High visibility

The glass PCAP touchscreen provides high visibility, durability, and functionality. The surface is resistant to scratches, water, and oil and prevents ingress of dirt. It is also very hygienic, as the surface can be cleaned by spraying disinfectant or wiping with a wet cloth soaked in highly concentrated chemicals such as alcohol.



Clear visualization

The FT2J has a built-in 7-inch LCD used for the widest range of operator interface applications. The intuitive user interface provides the flexibility to customize graphs and other complex parts.



Excellent environmental resistance

Touchscreen with outstanding durability

Analog resistive touchscreens used in conventional products operate by making contact with the transparent electrode film, which causes mechanical deterioration due to movement with each operation. The PCAP touch panel uses a sensor board to detect changes in electric charge to identify the position of the touch. The hard glass surface, without movement, is resistant to mechanical deterioration, allowing for agile operation and multi-touch sensing.

In addition, PCAP touchscreens prevent unintended activation by water droplets, and gloves less than 1.5mm thick can be used. (*1)

*1) The touchscreen may not work with gloves less than 1.5mm thick depending on the material or environment. Check the operation in the actual environment or similar conditions.

PCAP touchscreen

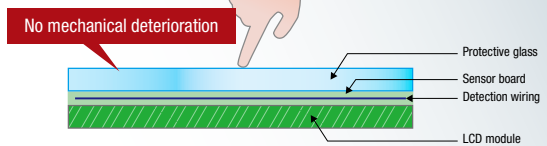

Analog resistive touchscreen

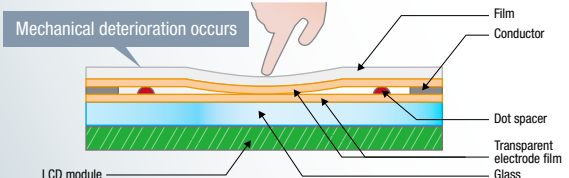

Retains its beauty for years

Conventional products with a plastic film on the surface will cloud over time, reducing visibility due to UV exposure. In contrast, the surface of the FT2J has a glass top structure that maintains high visibility and prevents deterioration and clouding from UV rays over a long period of time. (*2)



*2) If the product is used in a location where it may be exposed to UV rays for a long period of time (e.g., near a window), apply a UV protective film to prevent degradation of non-glass parts.

Wide operating temperature range

Suitable for use in hot and cold environments ranging from -20 to +55°C. (*3)



*3) No freezing.

High water resistance

IP66F / IP67F protection.
Resistant to direct water jets.



Seamless communication with various devices

Extensive communication interfaces

Communication interfaces such as RS232C, RS422/485, Ethernet, and USB-A ports enable easy connection to various external devices.

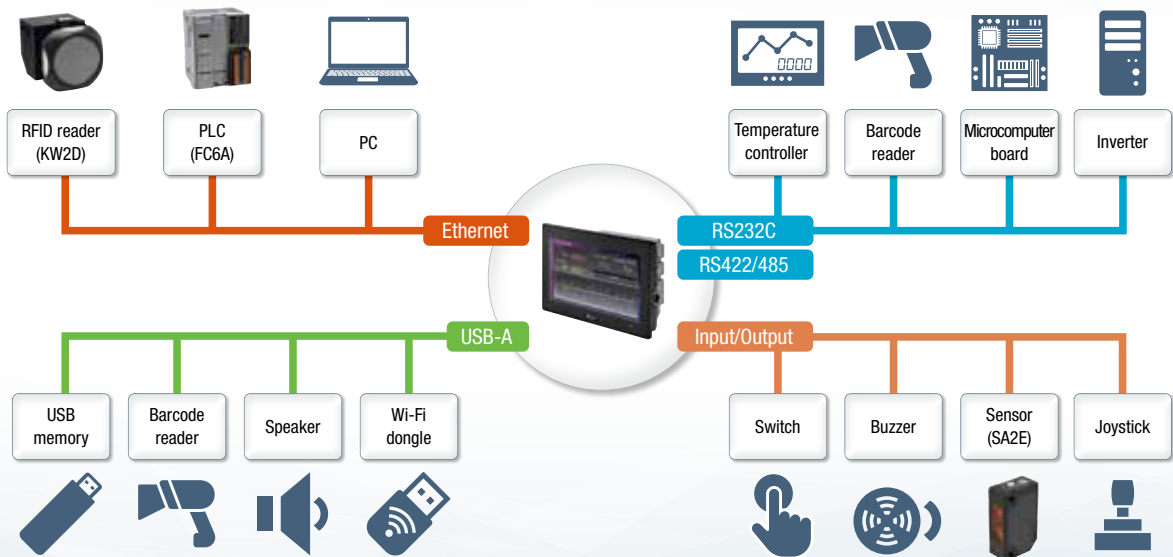

IoT-compatible

A wide range of IoT functionalities enable seamless integration of devices.



*1) Subject to change due to specification and service updates.

*1) Available in Automation Organizer software.

Simultaneous view of OI and ladder programs

Efficient programming can be achieved by referencing the OI and ladder program simultaneously.



User communication function supports custom protocols

Devices can communicate with unsupported or custom protocols by setting send and receive commands with the user communication function.

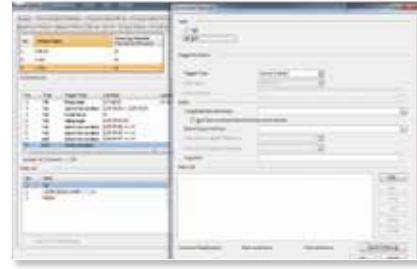

The error log helps to identify problems in a project

The error check function displays incorrectly setup or missed items in a list. This helps quickly resolve problems in a large project by finding the error directly from the list.



Script function enables easy programming of complex processes

The script function enables easy programming of complicated processing, such as conditional branching, logical and arithmetic operations, and functions. The script debug function lets you debug your script step-by-step during simulation mode.

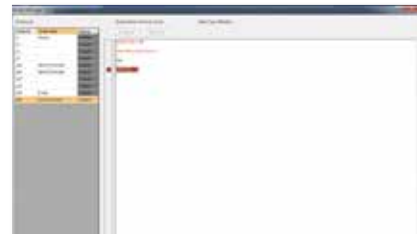

Extensive image library

Drag and drop functionality allows intuitive layout of parts represented by beautiful images. Additionally, over 10,000 images can be imported from the library tools to the parts library.



Easily copy data from devices in batches using the data copy setting

Ladder programs for communication devices can be copied in batches using the data copy setting, eliminating the need to copy data one at a time and saving significant programming time.

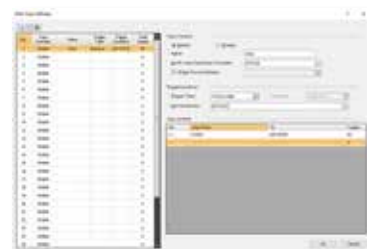

FT2J Controller with Operator Interface

Control and HMI functions in one with uncompromising design for a wide range of applications

Brightness 500 cd/m ²	TFT 65,536 colors	LED 50,000 hours	48-level Brightness Adjustment	Real Parts
Outlined font	WVGA 800×480	Serial Interface	Ethernet	USB A 2 ports
USB Memory	User Memory 24MB/96kB	Front Panel Maintenance	Operating Voltage 24V DC	Operating Temperature -20~+55°C



(for main unit only)

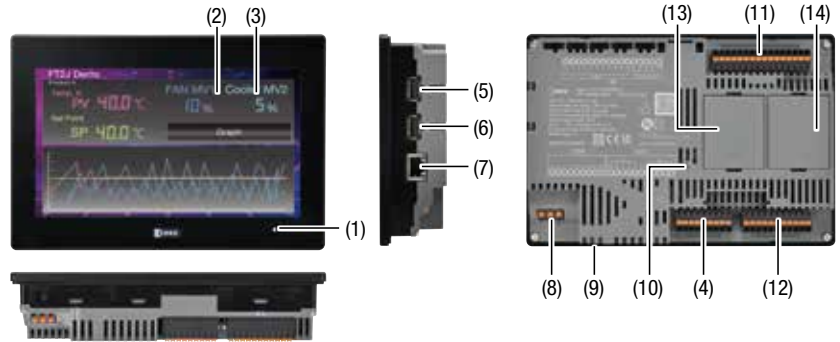

No.	Name	No.	Name
(1)	POWER LED	(8)	Power supply terminal
(2)	Display	(9)	Mounting bracket mounting position
(3)	Touchscreen	(10)	RESET switch
(4)	Serial interface (COM)	(11)	Input terminal (IN)
(5)	USB interface (USB1)	(12)	Output terminal (OUT)
(6)	USB interface (USB2)	(13)	Cartridge slot (Slot 1)
(7)	Ethernet interface (LAN)	(14)	Cartridge slot (Slot 2)

FT2J

Main unit

Quantity: 1

Display screen	Operation style	Communication interface	Bezel color	Approvals	Input specifications		Output	Part No.
					Digital input	Analog input		
7-inch wide TFT color LCD 65,536 colors	PCAP touchscreen (Projected capacitive)	Serial interface (RS232C, RS422/485), Ethernet, USB	Black	UL61010-1 UL61010-2-201 UL121201 CSA C22.2 No.61010-1 CSA C22.2 No.61010-2-201 CSA C22.2 No.213	10 point (sink/source)	4 point	8 point 2A relay output	FT2J-7U22RAF-B
							6 point transistor sink output 2 point analog output	FT2J-7U22KAF-B
							6 point transistor source output 2 point analog output	FT2J-7U22SAF-B

Dimensions

All dimensions in mm.

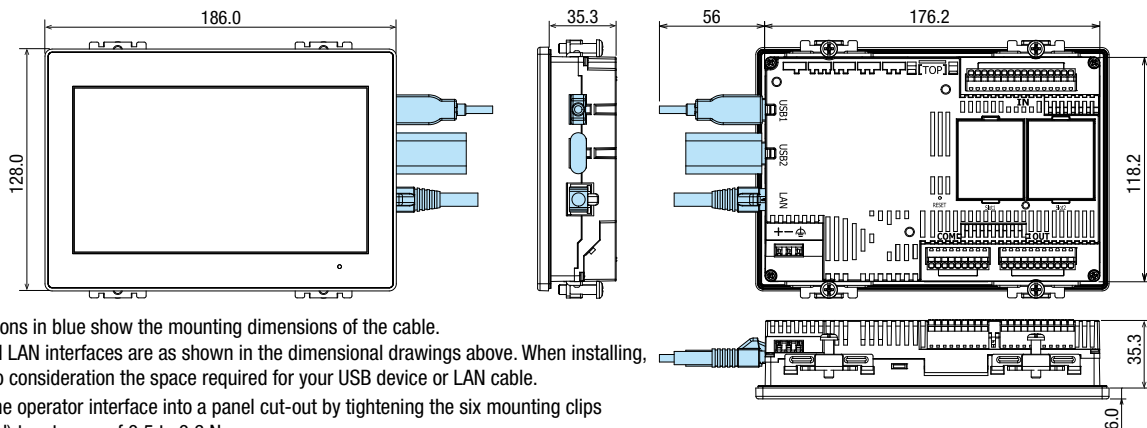

- Dimensions in blue show the mounting dimensions of the cable. USB and LAN interfaces are as shown in the dimensional drawings above. When installing, take into consideration the space required for your USB device or LAN cable.
- Install the operator interface into a panel cut-out by tightening the six mounting clips (supplied) to a torque of 0.5 to 0.6 N·m. Do not tighten with excessive force, otherwise the main unit may become distorted and waterproof characteristics may be lost.

Mounting hole layout

All dimensions in mm.

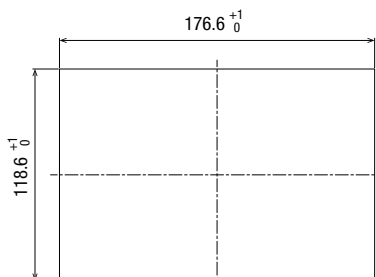

- Panel Thickness: 1.0 to 5.0 mm

General Specifications

Electrical	Rated power voltage	24V DC	
	Power voltage range	20.4 to 28.8V DC	
	Power consumption	Backlight off 3W maximum when not using USB1, USB2, IN, OUT, Slot 1, Slot 2	
		5W when not using USB1, USB2, IN, OUT, Slot 1, Slot 2 17W maximum	
Allowable instantaneous blackout period	10ms maximum (power supply voltage: 24.0V to 28.8V DC) 5ms maximum (power supply voltage: 20.4V to 24.0V DC)		
Environmental	Inrush Current	40A maximum	
	Dielectric strength	500V AC, 5mA, 1 minute between power and FG terminals 500V AC, 5mA, 1 minute between input and FG terminals 2300V AC, 5mA, 1 minute between relay output and FG terminals 500V AC, 5mA, 1 minute between transistor output and FG terminals 500V AC, 5mA, 1 minute between power and input terminals 2300V AC, 5mA, 1 minute between power and relay output terminals 500V AC, 5mA, 1 minute between power and transistor output terminals 2300V AC, 5mA, 1 minute between input and transistor output terminals 2300V AC, 5mA, 1 minute between input and relay output terminals	
		Operating temperature	-20 to +55°C (no freezing)
		Operating humidity	10 to 95%RH (no condensation)
Storage temperature		-20 to +70°C (no freezing)	
Mechanical	Storage humidity	10 to 95%RH (no condensation)	
	Pollution degree	2	
	Corrosion immunity	Free from corrosive gases	
	Vibration resistance	5 to 8.4Hz single amplitude 3.5mm, 8.4 to 150Hz acceleration 9.8m/s ² (10 times each in 3 axes) (IEC61131-2)	
Shock resistance		147m/s ² 11ms (3 times in each in 3 axes) (IEC61131-2)	
Noise	First transient/burst	±2kV (power supply terminal) ±1kV (communication line)	
	Electrostatic discharge	±6kV (contact discharge) ±8kV (air discharge)	
Structure	Mounting	Panel mount (panel thickness: 1.0 to 5.0mm)	
	Degree of Protection	When panel thickness is between 1mm and 1.6mm: IP65F (IEC 60529) When panel thickness is between 1.6mm and 5mm: IP66F, IP67F (IEC 60529), TYPE 4X (indoor use only), TYPE 13	
	Dimensions	186 (W) x 128 (H) x 41.3 (D) mm	
	Weight (approx.)	600g	

Display Specifications

Display	TFT color LCD	
Color / Shade	65,536 colors (16-bit color)	
Effective display area	154.08 (W) x 85.92 (H) mm	
Display resolution	800 (W) x 480 (H) dot	
Dot pitch	0.1926 (W) x 0.179 (H) mm	
View angle	Left/right/top: 80°, bottom 60°	
Backlight	White LED	
Backlight life	50,000 hours standard	
Brightness	500 cd/m ² (Typ.)	
Brightness adjustment	48 levels	
Character code	Shift_JIS (Japanese)	ANSI 1250 (Central European)
	ISO8859-1 (European)	ANSI 1257 (Baltic)
	GB2312 (Simplified Chinese)	ANSI 1251 (Cyrillic)
	BIG5 (Traditional Chinese)	ASCII (7 seg)
	KSC5601 (Hangul)	
Character size	8 to 512	
Character attribute	Bold, shadowed, blink (1 or 0.5 sec period)	
Graphics	Straight line, continuous line, rectangle, circle, arc, fan, ellipse, equilateral polygon (3, 4, 5, 6, 8), bitmap shape	
Window display	3 popup screens + 1 system screen	

Operation Specifications

Switching element	PCAP touchscreen (projected capacitive)
Multiple press	Up to 2 points
Acknowledgment sound	Electronic buzzer

Function Specifications

Screen types	Base screen, popup screen, system screen
Number of screens	Base screen: 3,000 maximum Popup screen: 3,015 maximum
User memory	HMI function :24MB approx. Control function : 96KB (equivalent to 12,000 steps)
Parts	Bit Button, Word Button, Goto Screen, Print Button, Key Button, Multi Button, Keypad, Numerical Input, Character Input, Pilot Lamp, Multi-State Lamp, Picture Display, Message Display, Message Switching Display, Alarm List Display, Alarm Log Display, Data Log Display, Numerical Display, Bar Graph, Trend Chart, Pie Chart, Meter, Calendar, Bit Write Command, Word Write Command, Goto Screen Command, Print Command, Timer, Screen Script Command, Multi Command
Backup data (Stored in nonvolatile memory)	HMI function: HMI keep relay, HMI keep register, log data Control function: Internal relay, shift register, counter, data register, special data register, special internal relay
Calendar (Stored in a large capacity capacitor)	Year, Month, Day, Hour, Min., Sec., Day of Week ±60 sec per month (at 25°C)
Clock backup time	20 days (at operating temperature of 25°C) (*1)

*1) If the power is cut off for a certain amount of time, the clock data will be initialized to "00:00:00 January 1, 2000" at the next start up. Log data, HMI keep relay, HMI keep register is stored in a volatile memory so there is no backup time limit.

Interface Specifications

Serial interface (COM) (*2)	RS232C	Electrical characteristics	EIA RS232C compliant
		Transmission speed	1200/2400/4800/9600/ 19,200/38,400/57,600/ 115,200/187,500 bps (*3)
		Synchronization	Asynchronous
		Communication method	Half or full duplex
		Control system	Hardware control or none
		RS422 / 485	Electrical characteristics
	Transmission speed		1200/2400/4800/9600/ 19,200/38,400/57,600/ 115,200/187,500 bps (*3)
	Synchronization		Asynchronous
	Communication method		Half or full duplex
	Control system		None
	Connector		Detachable 9-pin terminal block
	Ethernet interface (LAN)	Interface specifications	IEEE802.3u (10BASE-T/100BASE-TX) compliant
Connector		Modular jack (RJ-45)	
USB interface (USB1) (*4)	Interface specifications	USB2.0 High speed (480Mbps)	
	Connector	USB Type A connector	
USB interface (USB2) (*4)	Interface specifications	USB2.0 High speed (480Mbps)	
	Connector	USB Type A connector	

*2) RS232C and RS 422/485 can be used simultaneously

*3) 187,500 bps is available only with SIEMENS SIMATIC S7-300/400 series (MPI port direct connection).

*4) USB output current varies depending on the mounting direction and ambient temperature.

Serial Interface Connector Terminal Arrangement

Name	I/O	Function	Communication
SD	OUT	Sent data	RS232C
RD.	IN	Receive data	
RS	OUT	Request to send	
CS	IN	Clear to send	
SG	-	Signal ground	RS232C, RS422/485
SDA	OUT	Send data "+"	RS422/485
SDB	OUT	Send data "-"	
RDA	IN	Receive data "+"	
RDB	IN	Receive data "-"	

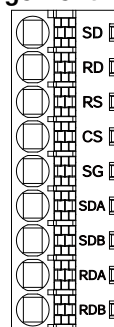

Performance Specifications

Part No.		FT2J-7U22RAF-B	FT2J-7U22KAF-B	FT2J-7U22SAF-B	
Instruction words (control function)	Basic instructions	42			
	Advanced instructions	109			
Number of user program downloads		1000 times			
Processing time (control function)	Basic instructions	100µs/1000 steps			
	END processing	2ms			
Built-in I/O points	Input	Digital	10 (sink/source common)		
		Analog/Digital common	4 (0 to 10VDC/4 to 20mA, 12-bit resolution) / (sink)		
	Output	Relay	8 (2A)	–	–
		Transistor sink	–	6	–
		Transistor source	–	–	6
Analog	–	2 (0-10V DC/4-20mA, 12-bit resolution)			
Cartridge	Number of slots	2			
	Connectable cartridge types	7 (Digital I/O cartridges: 3 analog I/O cartridges: 4)			
	Expandable I/O points	Digital I/O: 8 maximum Analog I/O: 4 maximum			
High-speed counter	Single/two-phase common	1 (2 times: 10kHz, 4 times: 5kHz)			
	Single phase only	4 (20kHz)			
Pulse output	Number of points	–	4		
	Maximum response frequency	–	20KHz		
	Function	–	PULS and PWM instructions		
Number of devices (control function)	Internal relay	6400			
	Special internal relay	144			
	Shift register	128			
	Data register	4000			
	Special data register	200			
	Additional/reversible counters	200			
	Timer (1ms, 10ms, 100ms, 1s)	200			

Input Specifications

Digital Input	Input points	10		
	Input type	Sink/source		
	Input voltage range	0 to 28.8V DC		
	Rated input current	IO to I5:	4mA / 1 point	
		I6, I7, I10, I11:	5mA / 1 point	
	Input impedance	IO to I5:	5.6kΩ	
		I6, I7, I10, I11:	4.3kΩ	
	Input delay time	OFF → ON	IO to I5: 25µs + soft filter setting I6, I7, I10, I11: 100µs + soft filter setting	
		ON → OFF	IO to I5: 25µs + soft filter setting I6, I7, I10, I11: 100µs + soft filter setting	
	Isolation	Between input terminals	Not isolated	
Internal circuit		Photocoupler-isolated		
Analog Input (common digital input)	Input type	Type1 (IEC 61131)		
	External load for I/O interconnection	Not needed		
	Operating level	OFF voltage	5V DC maximum	
		ON voltage	15V DC minimum	
		OFF current	IO to I5: 0.5mA maximum I6, I7, I10, I11: 0.9mA maximum	
		ON current	IO to I5: 2.2mA minimum I6, I7, I10, I11: 3.2mA minimum	
	Number of inputs	4		
	Input style	Voltage/current input (selectable)		
	Input range	0 to 10V DC / 4 to 20mA		
	Sampling duration time	5ms maximum		
Total input delay time	6ms + 1 scan time			
Analog resolution	4096 (12 bit)			
Input error	25°C	±3% of full scale		
	Total	±5% of full scale		
Isolation	Between input terminals	Not isolated		
	Internal circuit	Not isolated		
When used as digital input	Digital input type	Type 1 (not conforming to IEC 61131-2)		
	Operating Level	OFF voltage	5V DC maximum	
		ON voltage	15V DC minimum	
		OFF current	0.06mA maximum	
ON current		0.20mA minimum		

Output Specifications

Transistor output	Output type / points	Transistor sink	6	
		Transistor source	6	
	Rated load voltage	24V DC		
	Input voltage range	20.4 to 28.8V DC		
	Maximum load current	1 point	0.5A maximum	
		1 common	3A maximum	
	Voltage drop (ON voltage)	1V maximum (voltage between COM and output terminals when on)		
	Maximum inrush current	1A		
	Leakage current	0.1mA maximum		
	Inductive load	L/R = 10ms (28.8V DC, 1Hz)		
External current draw	100mA maximum 24V DC			
Isolation	Photocoupler-isolated			
Output delay time	OFF → ON	Q0 to Q3: 25µs maximum Q4 to Q5: 300µs maximum		
	ON → OFF	Q0 to Q3: 25µs maximum Q4 to Q5: 300µs maximum		
Output points	8			
Rated load current	240V AC 2A			
	30V DC 2A			
Minimum switching load	1mA/5V DC (reference value)			
Initial contact resistance	30mΩ maximum			
Electrical life	100,000 times min. (resistance load: 1800 operations/hour)			
Mechanical Life	20 million times min. (no load: 18000 operations/hour)			
Output points	2 points			
Output type	Voltage/current output (selectable)			
Output range	0 to 10V DC / 4 to 20mA			
Output load impedance	2kΩ minimum (voltage) 500Ω maximum (current)			
Output load type	Resistive load			
Maximum error at 25°C	±0.3% of full scale			
Temperature coefficient	±0.02% of full scale/°C			
Reproducibility after stability time	±0.4% of full scale			
Non-linearity	±0.01% of full scale			
Output ripple	30mV maximum			
Overshoot	0% (*1)			
Overall accuracy	±1.0% of full scale			
Effects of improper output connection	None			
Digital resolution	4096 (12 bit)			
Monotonicity	Yes			
Open current loop	Cannot be detected			

*1) Overshoot may occur under light load conditions. Overshoot can be suppressed by inserting a damping resistor. Damping resistor value: approx. 150Ω including the input impedance.

Cartridge

Digital I/O Cartridge Specifications

Input Cartridge

Part No.	FC6A-PN4	
Input points	4 points (4/1 common)	
Rated input voltage	12/24V DC sink/source common	
Operating input voltage range	0 to 28.8V DC	
Rated input current	2.5mA / 1 point (12V DC) 5mA / 1 point (24V DC)	
Input impedance	4.4kΩ	
Operating level	OFF voltage	Less than 5V
	ON voltage	8.5V minimum
	OFF current	Less than 0.9mA
	ON current	1.7mA minimum (at applied voltage of 8.5V)
Input delay time (24V DC)	OFF → ON	0.5ms
	ON → OFF	0.5ms
Isolation	Between channels: Not isolated Internal circuit: Photocoupler-isolated	
I/O connection	No external load required for I/O interconnection	
Signal determination method	Static	
Effect of improper input connection	Both sink and source can be connected. However, if voltage exceeding the rated value is applied, permanent damage may be caused.	
Cartridge internal current draw	All ON	35mA (3.3V DC) 0mA (5V DC)
	All OFF	30mA (3.3V DC) 0mA (5V DC)
Cartridge internal power consumption (at 24V DC while all inputs are ON)	0.10W	
Cable length	3m in compliance with electromagnetic immunity	
Applicable rod terminal	For 1-wire: AI 0.5-8 WH (Phoenix Contact)	
Weight (approx.)	15g	

Output Cartridge

Part No.	FC6A-PTK4	FC6A-PTS4
Output points	4 points sink output (4/1 common)	4 points source output (4/1 common)
Rated load voltage	12/24V DC	
Input voltage range	10.2 to 28.8V DC	
Load current	1 point	0.1A maximum
	1 common	0.4A maximum
Output delay time	ON → OFF	450us maximum
	OFF → ON	450us maximum
Isolation	Between input terminals: Non-isolated Internal circuit: Photocoupler-isolated	
Voltage drop (ON voltage)	1V maximum (voltage between COM and output when on.)	
Allowable inrush current	1A maximum	
Leakage current	Less than 0.1mA	
Clamping voltage	Approx. 50V	
Lamp load	2.4W maximum	
Inductive load	L / R=10ms (28.8V DC, 1Hz)	
External current draw	100mA maximum 24V DC (+V terminal supply power)	100mA maximum 24V DC (-V terminal supply power)
	Overcurrent protection: No	
Cartridge internal current draw	All outputs ON	35mA (3.3V DC) 0mA (5V DC)
	All outputs OFF	30mA (3.3V DC) 0mA (5V DC)
Cartridge internal power consumption: (at 24V DC while all outputs ON)	0.10W	
Applicable rod terminal	For 1-wire: AI 0,5-6 (manufactured by Phoenix Contact)	
Weight (approx.)	15g	

Cartridge

Analog Cartridge

Performance Specifications

Part No.	FC6A-PJ2A		FC6A-PJ2CP		FC6A-PK2AV		FC6A-PK2AW	
Type	Voltage / current input		Temperature input		Voltage output		Current output	
I/O points	2		2		2		2	
Rated voltage	5.0V, 3.3V (supplied from main unit)							
Current draw	5.0V: – 3.3V: 30mA				5.0V: 70mA 3.3V: 30mA		5.0V: 185mA 3.3V: 30mA	
Weight	15g							

Input Specifications

Part No.	FC6A-PJ2A		FC6A-PJ2CP	
Type	Voltage input		Resistance thermometer	
Input range	0 to 10V DC	4 to 20mA DC 0 to 20mA DC	Thermocouple	
Input impedance	1MΩ minimum	250Ω maximum	1MΩ minimum	
Allowable conductor resistance	–		10Ω maximum	
Input detection current	–		Typ:0.2mA, 1.0mA maximum	
AD Conversion	Sampling duration time	10ms	250ms	
	Sampling interval	20ms	500ms	
	Total input delay time	20ms + scan time		500ms + scan time
	Type of input	Single-ended input		
	Operation mode	Self-scan		
	Conversion method	SAR		
Input error	Maximum error at 25°C	±0.1% of full scale	±0.1% of full scale	
	Temperature coefficient	±0.02%/°C of full scale		
	Reproducibility after stabilization time	±0.5% of full scale		
	Non-linearity	±0.01% of full scale		
	Total error	±1.0% of full scale		
	Digital resolution	4096 (12 bits)		K: 15,000 (14 bits) J: 12,000 (14 bits) R: 17,600 (15 bits) S: 17,600 (15 bits) B: 18,200 (15 bits) E: 10,000 (14 bits) T: 6000 (13 bits) N: 15,000 (14 bits) C: 23,150 (15 bits)
Data	LSB input value	2.44mV (0 to 10V DC)	4.88µA (0 to 20mA DC) 3.91µA (4 to 20mA DC)	0.1°C 0.18°F
	Data format in application	Can be arbitrarily set for each channel in the range of –32,768 to 32,773		
	Monotonicity	Yes		
	Maximum temporary Deviation during electrical noise tests	±4.0% of full scale maximum		
Noise resistance	Recommended cable	Shielded	–	
	Crosstalk	1 LSB maximum		
	Insulation	None		
Effect when input is incorrectly wired	No damage			
Maximum allowable constant load (non-destructive)	13V DC	40mA	13V DC	
Input type modification	Soft programming			
Calibration to maintain rated accuracy	Impossible			







Output Specifications

Part No.	FC6A-PK2AV		FC6A-PK2AW	
Type	Voltage output		Current output	
Output type	Voltage output	0 to 10V DC		–
	Current output	–		4 to 20mA DC
Load	Impedance	2kΩ minimum		500Ω maximum
	Load type	Resistive load		
D/A conversion	Scan time	20ms		
	Settling time	40ms maximum	20ms maximum	
	Total output delay time	60ms + Scan time	40ms + Scan time	
Output error	Maximum error at 25°C	±0.3% of full scale		
	Temperature coefficient	±0.02% / °C of full scale		
	Reproducibility after stability time	±0.4% of full scale		
	Non-linearity	±0.01% of full scale		
	Output ripple	30mV maximum		
	Overshoot	0%		
	Overall accuracy	±1.0% of full scale		
Data	Effect of improper output terminal connection	No damage		
	Digital resolution	4096 (12 bits)		
	LSB output value	2.44mV (0 to 10V)	3.91µA (4 to 20mA)	
	Data format in application	0 to 4095 (0 to 10V)	0 to 4095 (4 to 20mA)	
	Monotonicity	Yes		
Noise Resistance	Open current loop	–	Not detectable	
	Maximum temporary deviation during electrical noise tests	±4.0% of full scale maximum		
	Recommended cables	Shielded		
Crosstalk	1 LSB maximum			
Isolation	None			
Calibration to maintain rated accuracy	Impossible			
Selection of output signal type	Voltage output only		Current output only	

Applicable wire

Part No.	FC6A-PJ2A	FC6A-PJ2CP	FC6A-PK2AV	FC6A-PK2AW
Applicable wires and specifications	0.3mm ² (AWG20 to 24) Shielded	0.3mm ² (AWG20 to 24) Shielded	0.3mm ² (AWG20 to 24) Shielded	

Accessories





Name / Shape		Part No. (Ordering No.)	Quantity	Specification
System integration software		SW1A-W1C	1	Automation Organizer (Includes WindO/I-NV4)
Protective sheet		HG9Z-2D7PN05	5	For 7.0 inch screen. Used to protect the LCD from UV light. Includes 5 pcs. Dimensions: 182.4 x 124.4 mm, sheet thickness: 0.153 mm
UV protective sheet		FT9Z-2D7PN05		For 7.0 inch screen, used to protect the LCD from UV light. Water adhesive. Includes 5 pcs. Dimensions: 182.4 x 124.4 mm, sheet thickness: 0.153 mm
USB relay port		CW1X-USB20-1M	1	Bezel color: black
		CW4X-USB20-1M		Bezel color: metallic
RJ45 relay port		CW1X-RJ45	1	Bezel color: black
		CW4X-RJ45		Bezel color: metallic
Rubber cap (*1)		CW9Z-D1X1	1	Material: TPE Color: black Protection: IP65/67
Plastic cover (*1)		CW9Z-D1X2	1	Material <Lens> Polycarbonate resin <Body> Polyamide resin <Packing>NBR Color : Translucent Protection: IP65/67
Digital I/O cartridge	Digital input	FC6A-PN4	1	Digital input (4 points)
	Digital output	FC6A-PTK4	1	Transistor sink output (4 points)
		FC6A-PTS4	1	Transistor source output (4 points)
Analog cartridge		FC6A-PJ2A	1	Voltage current input (2 points)
		FC6A-PK2AV	1	Voltage output (2 points)
		FC6A-PK2AW	1	Current output (2 points)
		FC6A-PJ2CP	1	Temperature input (2 points)

*1) Exclusive for CW series relay ports (CW1X /CW4X) and cannot be used for other models.

Refer to the instruction manual from the QR code on the right for details on how to use the product.



Maintenance Parts

Name	Shape	Part No. (Ordering No.)	Quantity	Specification
Mounting clip		HG9Z-4K2PN04	4	Four clips are supplied with the main unit.
Serial interface connector		HG9Z-XT09P	1	Removable terminal block 9-pin, push-in type One plug is supplied with the main unit..
Input terminal connector		FT9Z-XT16P	1	Detachable terminal block 16-pin, push-in type One plug is supplied with the main unit.
Output terminal connector		FT9Z-XT11P	1	Detachable terminal block 11-pin, push-in type One plug is supplied with the main unit.

List of PLCs that can be connected

Manufacturer	Series
IDEC	MICROSmart FC6A
	SmartAXIS FT1A Pro/Lite
	MICROSmart FC6A (Ethernet)
	SmartAXIS FT1A Pro/Lite (Ethernet)
Mitsubishi Electric	MELSEC-A (Link Unit)
	MELSEC-QnA (Link Unit)
	MELSEC-Q (Link Unit)
	MELSEC-Q (Ethernet)
	MELSEC-FX
Omron	MELSEC-FX (Ethernet)
	SYSMAC-C
	SYSMAC-CS
	SYSMAC-CJ1
	SYSMAC-CJ2
	SYSMAC-CP1
Allen-Bradley	SYSMAC (Ethernet)
	PLC-5 (Half Duplex)
	SLC-500 (Half Duplex)
	MicroLogix (Full Duplex)
	ControlLogix (Full Duplex)
	CompactLogix (Full Duplex)
	FlexLogix (Full Duplex)
	ControlLogix (Ethernet/IP, Ethernet/IP (Logix Native Tag))
	CompactLogix (Ethernet/IP, Ethernet/IP (Logix Native Tag))
	PLC-5 (Ethernet/IP)
SLC 500 (Ethernet/IP)	
MicroLogix (Ethernet/IP)	

Manufacturer	Series
SIEMENS	S7-200
	S7-300 (connected to CPU unit)
	S7-300 (link unit)
	S7-400
	S7-1200 (Ethernet)
Keyence	KV-700/1000/3000/5000/7000
	KV Nano
	KZ
	KV-10 16
	KV (Ethernet)
Shibaura Machinery	TC200
	TCmini
Modicon	Modbus RTU Master (*1)
	Modbus RTU Slave (*2)
	Modbus ASCII Master (*1)
	Modbus TCP Client (*1)
	Modbus TCP Server (*2)
Panasonic	FP Series (MEWNET)
Yaskawa Electric	MP
	MP (Ethernet)
Fuji Electric	MICREX-SX
	MICREX-SX (Ethernet)
ABB	Totalflow G4/G5 (RS232C/485)
	Totalflow G4/G5 (Ethernet)

The compatible PLC information is for reference only (except for IDEC PLCs), and IDEC does not guarantee the operation of any other manufacturers' PLC. When using other manufacturers' PLCs, read their specifications and instruction manual carefully. The PLC must be operated correctly under the user's responsibility.

The company names and product names are registered trademarks or brand names.

*1) FT2J can be connected to slave or server devices.

*2) Master or client devices can be connected to FT2J.

See website for the latest information on compatible PLCs.

Terminal Layout and Wiring Example (For details, see the instruction manual.)

Fuse Load

FT2J-7U22RAF-B

FT2J-7U22KAF-B

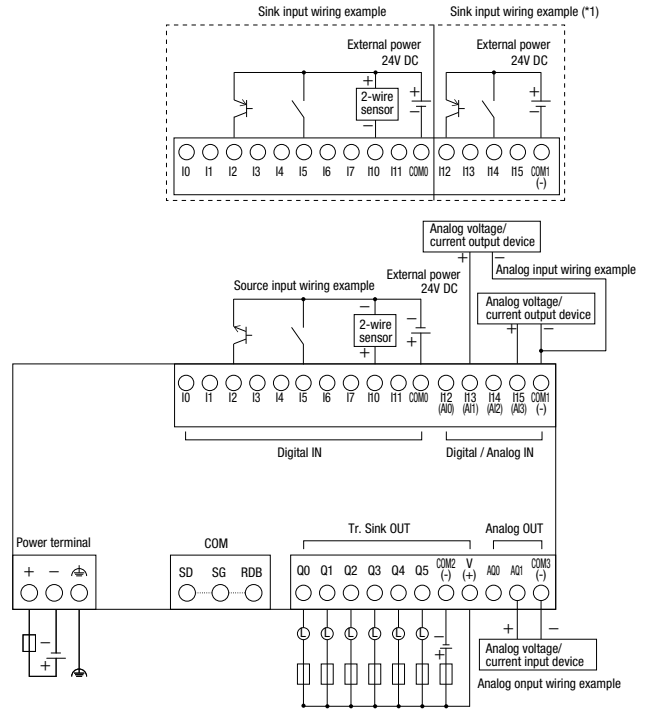
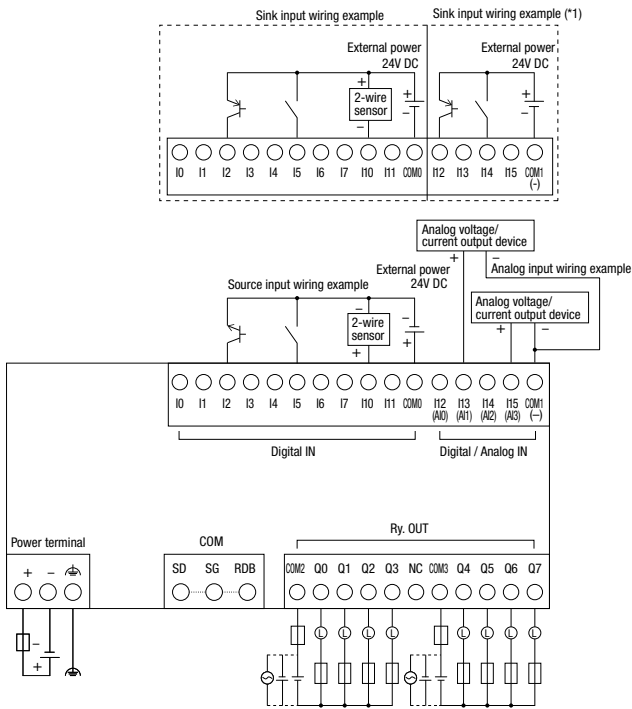

FT2J-7U22SAF-B

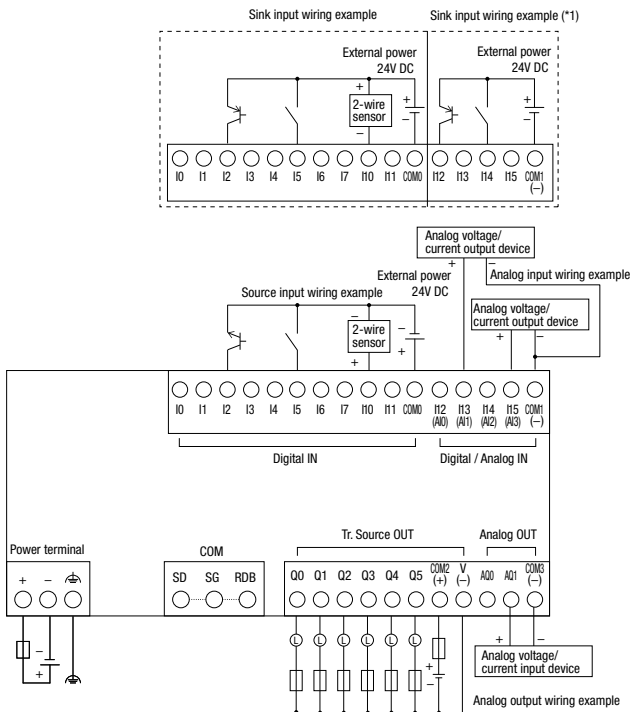

Recommended Rod Terminals and Crimping Tools

Applicable wire / Recommended ferrule

When wiring, use the applicable wires shown below. In addition, use the following applicable rod terminals for wiring to each terminal.

Applicable wire (*1)	Power supply unit : AWG14 to 28 Input terminal, output terminal, serial interface: AWG16 to 24		
Wire strip length (*1)	Power supply unit: 7 to 9mm Input terminal, output terminal, serial interface: 8 to 9 mm		
Recommended ferrule	IEDEC	Weidmüller	Phoenix Contact
	Part No.	Part No.	Part No.
	S3TL-H025-12WJ	H0.25/12 HBL	AI 0,25-8YE
	S3TL-H034-12WT	H0.34/12 TK	AI 0,34-8TQ
S3TL-H05-14WA	H0.5/14 OR	AI 0,5-8WH	
S3TL-H075-14WW	H0.75/14 W	AI 0,75-8GY	

*1) When single or stranded wires are used.

• I12 to I15 cannot be used as source inputs.

Recommended tools (sold separately)

Name	Part No.	Ordering No.	Manufacturer
Flat screwdriver	Standard model	SDS 0.4 x 2.5 x 75	2749320000 Weidmüller
	With insulation cover	S3TL-D04-25-75	S3TL-D04-25-75 IDEC
		SDIS 0.4x2.5x75	2749790000 Weidmüller
Crimping tool	S3TL-CR06D	S3TL-CR06D	IEDEC
Stripping tool	STRIPAX	S3TL-ST16	IEDEC

Instructions

Be sure to read the instruction manual carefully before performing installation, wiring, or maintenance work.

For details on mounting, wiring, and maintenance, see the instruction manual from the below URL.

URL: <https://product.idec.com/?product=FT2J-7U>



- This product has been manufactured under strict quality control. However, if you intend to use this product in applications where failure of this equipment may result in damage to property or injury, ensure that it used in conjunction with appropriate fail-safe backup equipment.
- Turn off the power before starting installation, removal, wiring, maintenance, and inspection of the products. There is a risk of electric shock or fire as well as damage to the equipment.
- Emergency and interlocking circuits must be configured outside of the FT2J.
- Do not use touch switches and the function keys for an emergency circuit or an interlocking circuit. If the FT2J fails, external equipment connected the product will no longer be protected, and serious injury to operators and equipment damage may be caused.
- Use the product within the environmental limits given in the catalog and manual. Use of the product in high-temperature or high-humidity environments, or in locations where it is exposed to condensation, corrosive gas or large shock loads, can create the risk of electrical shock or fire.
- The FT2J is designed for use in pollution degree 2. Use the FT2J in environments of pollution degree 2. (based on the IEC60664-1 rating)
- Install the FT2J according to the instructions in the User's Manual. Improper installation will result in falling, failure, electrical shock, fire hazard, or malfunction.
- Use a power supply of the rated value. Using a incorrect power supply may cause fire.
- The FT2J uses "PS2" as DC power supply. (based on the IEC / EN61131 rating)
- Use an IEC 60127 approved fuse on the power line outside the FT2J. (Applicable when the equipment embedded with the operator interface is shipped to Europe.)
- When exporting the FT2J to Europe, use an EU-approved circuit protector. (Applicable when the equipment embedded with the operator interface is shipped to Europe.)
- The touch panel built-in the FT2J is made of glass. The touch panel will break if exposed to excessive shock. Be careful when handling the FT2J.
- The protective film affixed on the display of the FT2J is used to protect the product from scratches during transportation. Remove the protective film before use. If the protective film is not removed, depending on the operating environment, the film may become cloudy and adhere to the display part, making it difficult to remove.
- Do not press or scratch the touch panel and protection sheet with a hard object such as a tool.
- Do not install the FT2J in areas subject to strong ultraviolet rays, as ultraviolet rays may impair the quality of the LCD.
- Note that small black and bright dots may show up on LCD Screen. This is not a failure or malfunction.
- The backlight life refers to the time until the brightness reduces by half the initial value. The backlight life is not guaranteed and refers to the time until the brightness reduces by half after use at 25°C. The actual life depends on operating environments and conditions.
- Protection degree refers to the front of the surface after mounting. Although the protection structure satisfies various testing conditions, operation is not guaranteed under certain environments. IP66F/IP67F oil proof structure satisfies oil proof test conditions. Conditions are listed in the appendix of Japanese Industrial Standard JIS C 0920. Operation is not guaranteed when using oil for a long period of time or oil that does not satisfy standards. Please test/check before use.
- Do not disassemble, repair or modify the product. This can create the risk of fire or electrical shock.

Ordering Terms and Conditions

Thank you for using IDEC Products.

By purchasing products listed in our catalogs, datasheets, and the like (hereinafter referred to as "Catalogs") you agree to be bound by these terms and conditions. Please read and agree to the terms and conditions before placing your order.

1. Notes on contents of Catalogs

- (1) Rated values, performance values, and specification values of IDEC products listed in this Catalog are values acquired under respective conditions in independent testing, and do not guarantee values gained in combined conditions.
Also, durability varies depending on the usage environment and usage conditions.
- (2) Reference data and reference values listed in Catalogs are for reference purposes only, and do not guarantee that the product will always operate appropriately in that range.
- (3) The specifications / appearance and accessories of IDEC products listed in Catalogs are subject to change or termination of sales without notice, for improvement or other reasons.
- (4) The content of Catalogs is subject to change without notice.

2. Note on applications

- (1) If using IDEC products in combination with other products, confirm the applicable laws / regulations and standards.
Also, confirm that IDEC products are compatible with your systems, machines, devices, and the like by using under the actual conditions. IDEC shall bear no liability whatsoever regarding the compatibility with IDEC products.
- (2) The usage examples and application examples listed in Catalogs are for reference purposes only. Therefore, when introducing a product, confirm the performance and safety of the instruments, devices, and the like before use. Furthermore, regarding these examples, IDEC does not grant license to use IDEC products to you, and IDEC offers no warranties regarding the ownership of intellectual property rights or non-infringement upon the intellectual property rights of third parties.
- (3) When using IDEC products, be cautious when implementing the following.
 - i. Use of IDEC products with sufficient allowance for rating and performance
 - ii. Safety design, including redundant design and malfunction prevention design that prevents other danger and damage even in the event that an IDEC product fails
 - iii. Wiring and installation that ensures the IDEC product used in your system, machine, device, or the like can perform and function according to its specifications
- (4) Continuing to use an IDEC product even after the performance has deteriorated can result in abnormal heat, smoke, fires, and the like due to insulation deterioration or the like. Perform periodic maintenance for IDEC products and the systems, machines, devices, and the like in which they are used.
- (5) IDEC products are developed and manufactured as general-purpose products for general industrial products. They are not intended for use in the following applications, and in the event that you use an IDEC product for these applications, unless otherwise agreed upon between you and IDEC, IDEC shall provide no guarantees whatsoever regarding IDEC products.
 - i. Use in applications that require a high degree of safety, including nuclear power control equipment, transportation equipment (railroads / airplanes / ships / vehicles / vehicle instruments, etc.), equipment for use in outer space, elevating equipment, medical instruments, safety devices, or any other equipment, instruments, or the like that could endanger life or human health
 - ii. Use in applications that require a high degree of reliability, such as provision systems for gas / waterworks / electricity, etc., systems that operate continuously for 24 hours, and settlement systems
 - iii. Use in applications where the product may be handled or used deviating from the specifications or conditions / environment listed in the Catalogs, such as equipment used outdoors or applications in environments subject to chemical pollution or electromagnetic interference
If you would like to use IDEC products in the above applications, be sure to consult with an IDEC sales representative.

3. Inspections

We ask that you implement inspections for IDEC products you purchase without delay, as well as thoroughly keep in mind management/maintenance regarding handling of the product before and during the inspection.

4. Warranty

- (1) Warranty period
The warranty period for IDEC products shall be one (1) year after purchase or delivery to the specified location. However, this shall not apply in cases where there is a different specification in the Catalogs or there is another agreement in place between you and IDEC.
- (2) Warranty scope
Should a failure occur in an IDEC product during the above warranty period for reasons attributable to IDEC, then IDEC shall replace or repair that product, free of charge, at the purchase location / delivery location of the product, or an IDEC service base. However, failures caused by the following reasons shall be deemed outside the scope of this warranty.
 - i. The product was handled or used deviating from the conditions / environment listed in the Catalogs
 - ii. The failure was caused by reasons other than an IDEC product
 - iii. Modification or repair was performed by a party other than IDEC
 - iv. The failure was caused by a software program of a party other than IDEC
 - v. The product was used outside of its original purpose
 - vi. Replacement of maintenance parts, installation of accessories, or the like was not performed properly in accordance with the user's manual and Catalogs
 - vii. The failure could not have been predicted with the scientific and technical standards at the time when the product was shipped from IDEC
 - viii. The failure was due to other causes not attributable to IDEC (including cases of force majeure such as natural disasters and other disasters)
 Furthermore, the warranty described here refers to a warranty on the IDEC product as a unit, and damages induced by the failure of an IDEC product are excluded from this warranty.

5. Limitation of liability

The warranty listed in this Agreement is the full and complete warranty for IDEC products, and IDEC shall bear no liability whatsoever regarding special damages, indirect damages, incidental damages, or passive damages that occurred due to an IDEC product.

6. Service scope

The prices of IDEC products do not include the cost of services, such as dispatching technicians. Therefore, separate fees are required in the following cases.

- (1) Instructions for installation / adjustment and accompaniment at test operation (including creating application software and testing operation, etc.)
- (2) Maintenance inspections, adjustments, and repairs
- (3) Technical instructions and technical training
- (4) Product tests or inspections specified by you

The above content assumes transactions and usage within your region. Please consult with an IDEC sales representative regarding transactions and usage outside of your region. Also, IDEC provides no guarantees whatsoever regarding IDEC products sold outside your region.

IDEC CORPORATION

Head Office 6-64, Nishi-Miyahara-2-Chome, Yodogawa-ku, Osaka 532-0004, Japan

USA	IDEC Corporation	Singapore	IDEC Izumi Asia Pte. Ltd.
EMEA	APEM SAS	Thailand	IDEC Asia (Thailand) Co., Ltd.
		India	IDEC Controls India Private Ltd.

 www.idec.com

China	IDEC (Shanghai) Corporation	Japan	IDEC Corporation
	IDEC Izumi (H.K.) Co., Ltd.		
Taiwan	IDEC Taiwan Corporation		

Specifications and other descriptions in this brochure are subject to change without notice.
Information in this brochure is current as of February, 2024.
2024 IDEC Corporation, All Rights Reserved.

EP1811-1

